

PERIODIC MAINTENANCE
for the
Kodak Professional 8670 PS THERMAL PRINTER
Kodak PICTURE MAKER PS4 PRINTER
and the
Kodak Image Magic EI 8651 DIGITAL COLOR PRINTER

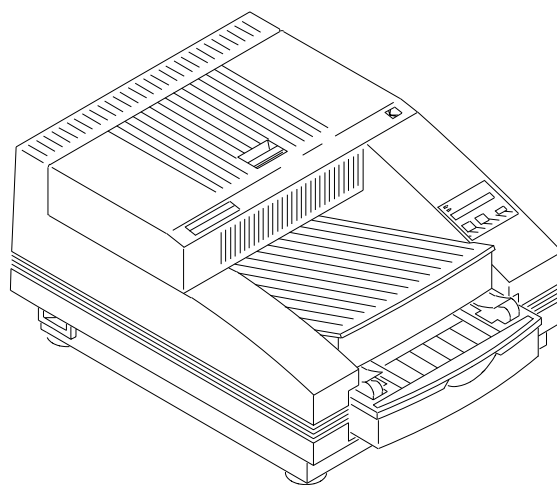

A087_2013AC



GLOBAL CUSTOMER SERVICE AND SUPPORT

PLEASE NOTE The information contained herein is based on the experience and knowledge relating to the subject matter gained by Eastman Kodak Company prior to publication.

No patent license is granted by this information.

Eastman Kodak Company reserves the right to change this information without notice, and makes no warranty, express or implied, with respect to this information. Kodak shall not be liable for any loss or damage, including consequential or special damages, resulting from any use of this information, even if loss or damage is caused by Kodak's negligence or other fault.

 This equipment includes parts and assemblies sensitive to damage from electrostatic discharge. Use caution to prevent damage during all service procedures.

Table of Contents

| Description | Page |
|--|-------------|
| Introduction/Cleaning Materials | 3 |
| Maintenance Procedures | 5 |
| Cleaning the THERMAL HEAD | 5 |
| Cleaning the CHUTE and ROLLER AY | 8 |
| Cleaning the PICKER AY | 8 |
| Cleaning the SIDE WALLS/RAILS | 9 |
| Cleaning the CONTROLLER ENCLOSURE AND DRAWER AY/CAVITY | 11 |

Section 1: Introduction/Cleaning Materials



Important

For the PRINTER to operate correctly, you must do the periodic maintenance procedure.

For references on image quality, see the procedure for Image Quality Troubleshooting in the DIAGNOSTICS, Publication No. DG3179-1.

Do this procedure when the PRINTER has:

- continual contamination problems
- artifacts on the prints

The materials necessary to do the maintenance procedures include:

- ALCOHOL PAD 2E5054
- DEIONIZED WATER PAD 5B5738
- ADJUSTMENTS AND REPLACEMENTS, Publication No. AR3179-1
- DIAGNOSTICS, Publication No. DG3179-1

Section 2: Maintenance Procedures

Cleaning the THERMAL HEAD



Warning

- Dangerous Voltage
- Possible damage from electrostatic discharge.

[1] De-energize and disconnect the PRINTER.

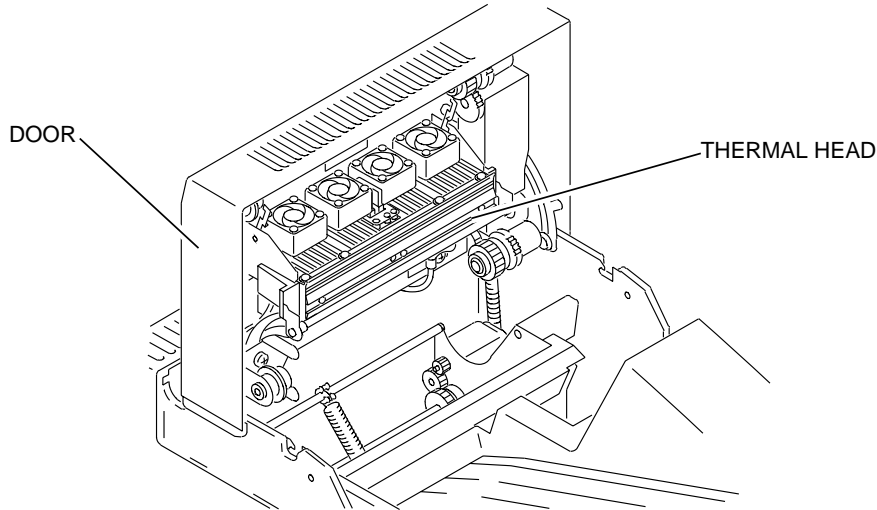

A087_0154BCB
A087_0154BC

[2] Open and lift the DOOR.

[3] Locate the THERMAL HEAD.

[4] Clean the THERMAL HEAD. Use:

- DEIONIZED WATER PAD 5B5738
- ALCOHOL PAD 2E5054

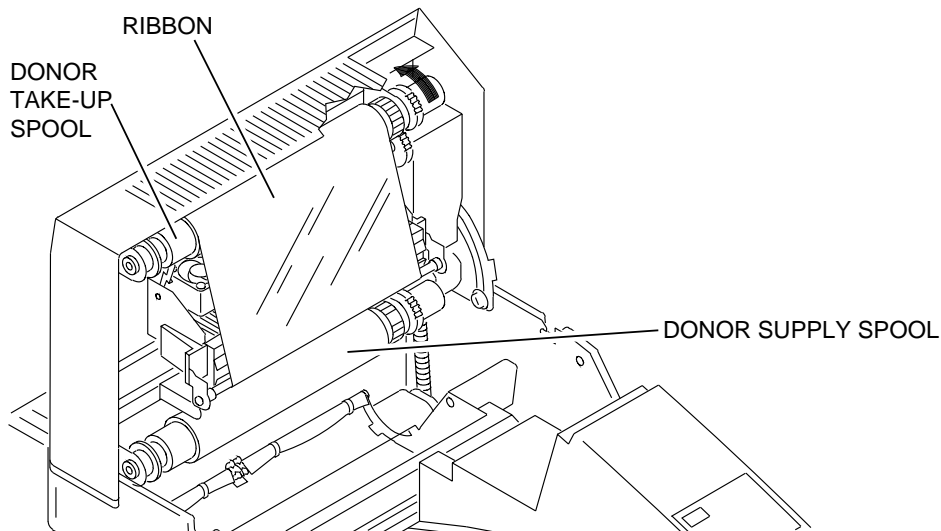

A087_4082BCB
A087_4082BC



Caution

Prevent contamination. Do not touch the RIBBON.

[5] Remove the RIBBON.

[6] Place the DONOR TAKE-UP SPOOL and the DONOR SUPPLY SPOOL with the ends in the up position on a surface that is not contaminated.

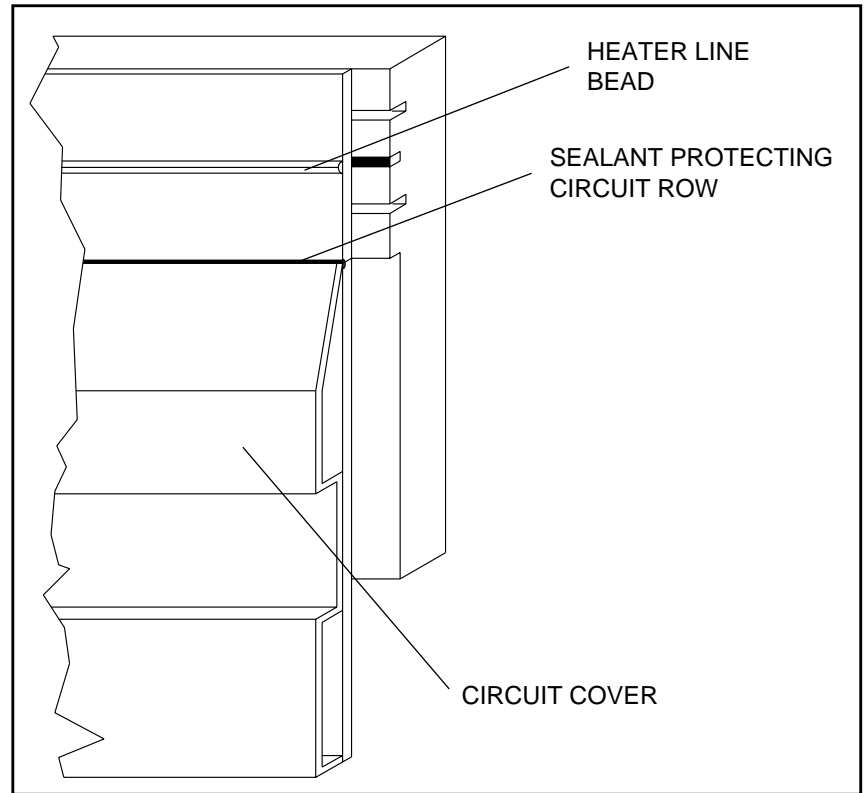
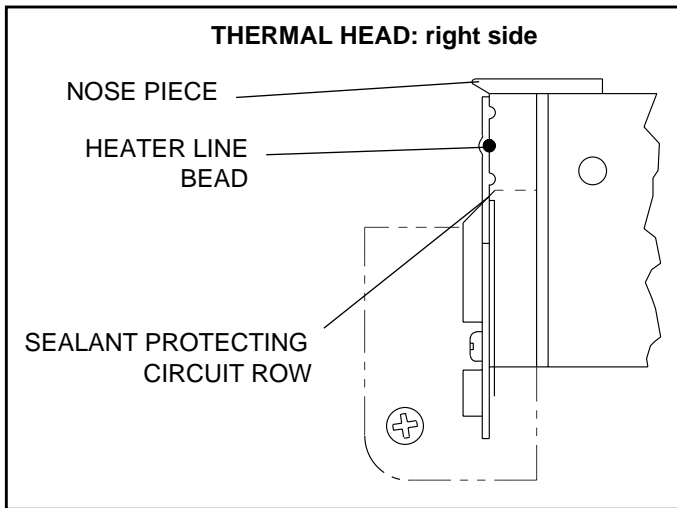
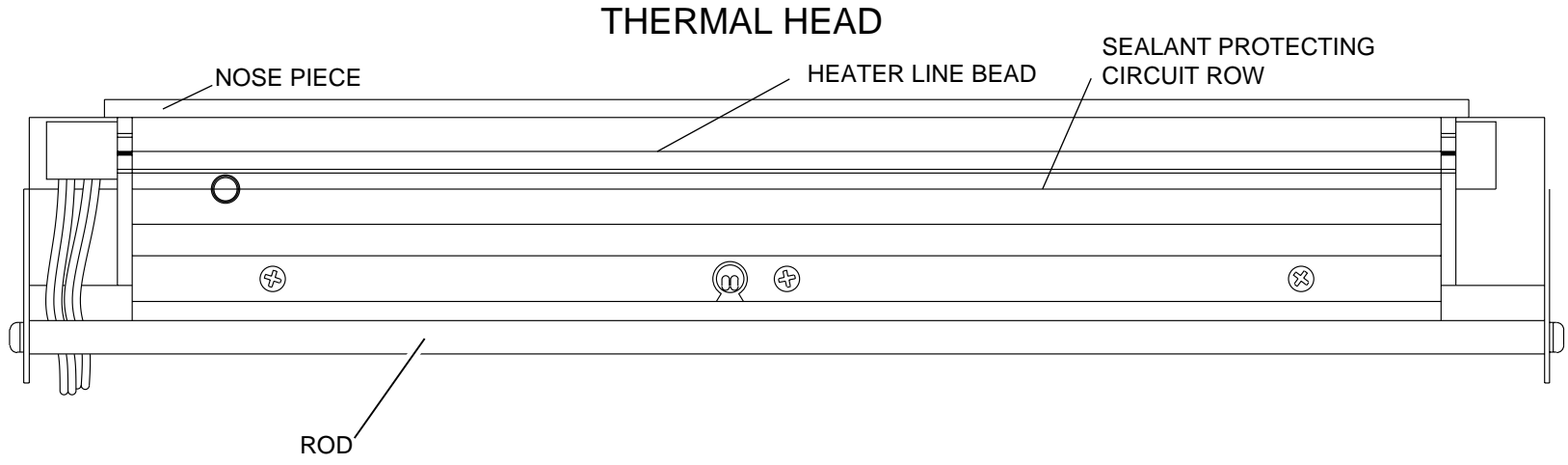

A087_0156ECB
A087_0156EC

**Caution**

Prevent damage:

- do not touch the SEALANT PROTECTING CIRCUIT ROW below the HEATER LINE BEAD
- do not press on the CIRCUIT COVER

[7] Check for contamination on the HEATER LINE BEAD.

[8] To clean the HEATER LINE BEAD:

- (a) Use the DEIONIZED WATER PAD a minimum of 4 times in 1 direction the length of the BEAD.
- (b) Wait 2 minutes for the BEAD to dry.
- (c) Use the ALCOHOL PAD a minimum of 4 times in 1 direction the length of the BEAD.
- (d) Wait 2 minutes for the BEAD to dry.

[9] Using the DEIONIZED WATER PAD and the ALCOHOL PAD, clean:

- NOSE PIECE
- ROD

[10] Install the RIBBON.

[11] Close the DOOR.

**Warning**

Dangerous Voltage

[12] Connect and energize the PRINTER.

[13] Make a test print to check that the artifacts are removed.

[14] If the artifacts are not removed:

- check the HEATER LINE BEAD with light and magnification.
- do step 8 again.

Cleaning the CHUTE and ROLLER AY

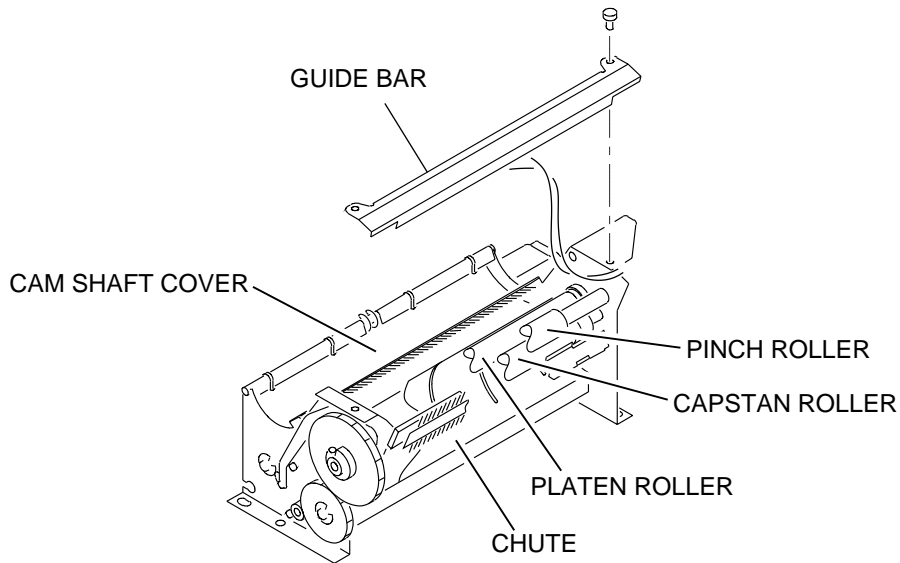

A087_1501BCA
A087_1501BC

[1] Remove the ENCASUREMENT. See the ADJUSTMENTS AND REPLACEMENTS, Publication No. AR3179-1.

[2] Using the DEIONIZED WATER PAD and the ALCOHOL PAD, clean:

- GUIDE BAR
- CHUTE
- PINCH ROLLER
- CAPSTAN ROLLER
- PLATEN ROLLER
- CAM SHAFT COVER

[3] Install the ENCASUREMENT. See the ADJUSTMENTS AND REPLACEMENTS, Publication No. AR3179-1.

Cleaning the PICKER AY

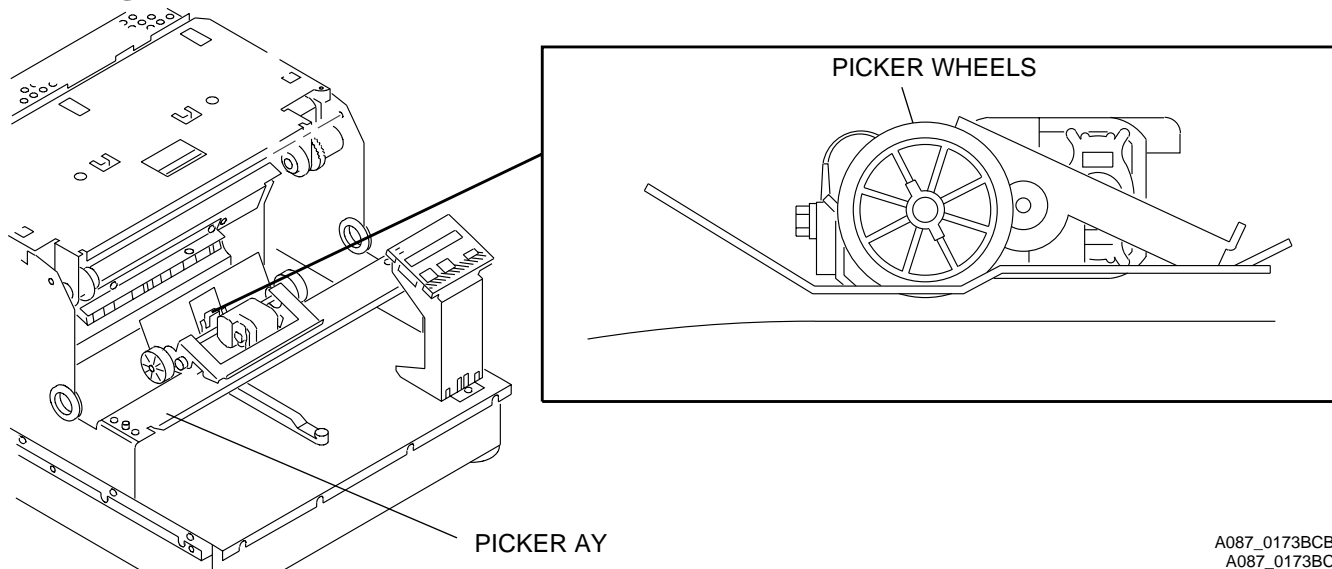

A087_0173BCB
A087_0173BC

[1] Clean:

- all metal parts of the PICKER AY - use the ALCOHOL PAD
- PICKER WHEELS - use the DEIONIZED WATER PAD

Cleaning the SIDE WALLS/RAILS

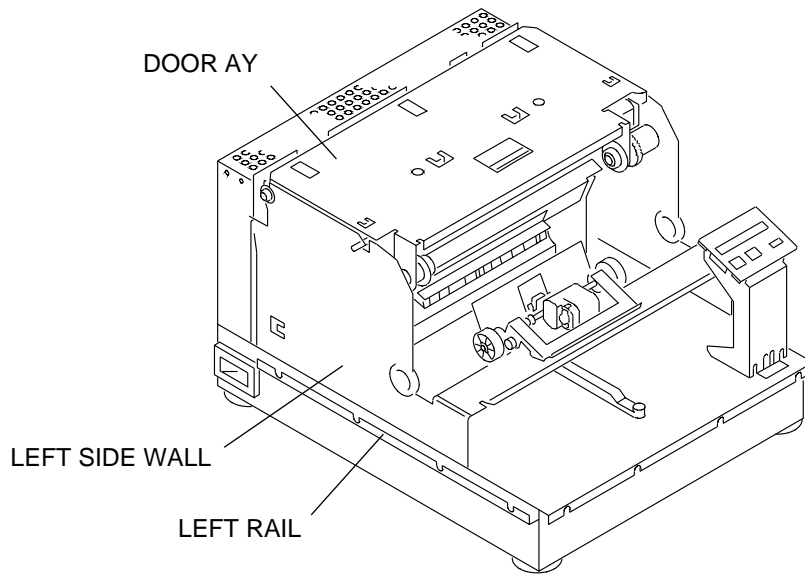

A087_0164BCB
A087_0164BC

- [1] Remove the ROLLER AY. See the ADJUSTMENTS AND REPLACEMENTS, Publication No. AR3179-1.
- [2] Clean the following parts. Use the ALCOHOL PAD.

- DOOR AY
- LEFT SIDE WALL
- LEFT RAIL

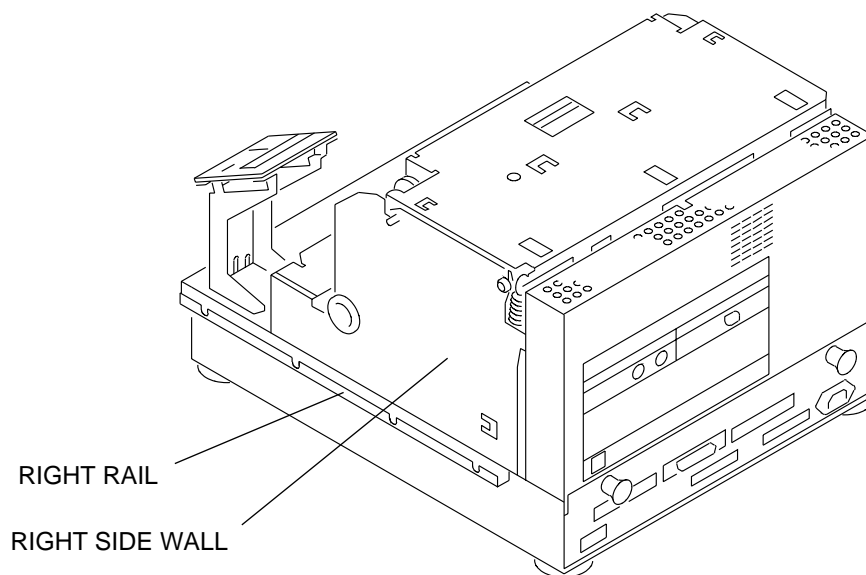

A106_0024BCA
A106_0024BC

- [3] Clean the following parts. Use the ALCOHOL PAD.
- RIGHT SIDE WALL
 - RIGHT RAIL

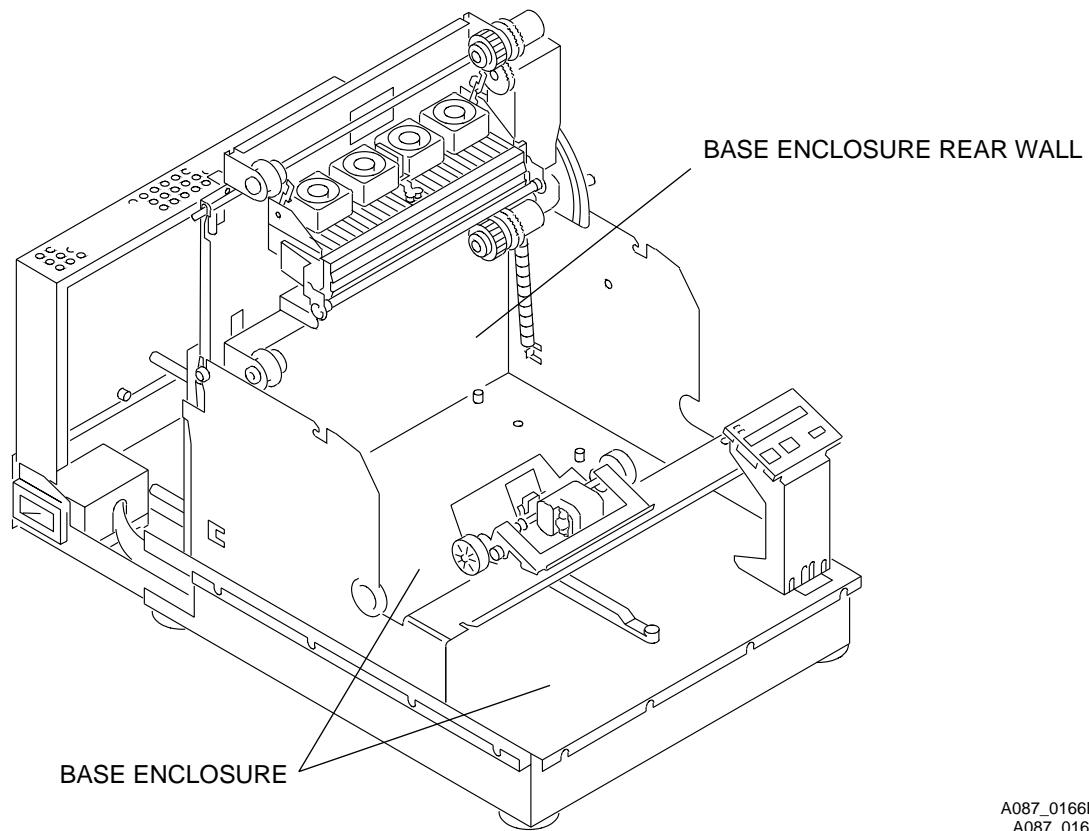

A087_0166HCC
A087_0166HC

[4] Clean the following parts. Use the ALCOHOL PAD.

- BASE ENCLOSURE REAR WALL
- BASE ENCLOSURE

[5] Install the ROLLER AY. See the ADJUSTMENTS AND REPLACEMENTS, Publication No. AR3179-1.

Cleaning the CONTROLLER ENCLOSURE AND DRAWER AY/CAVITY

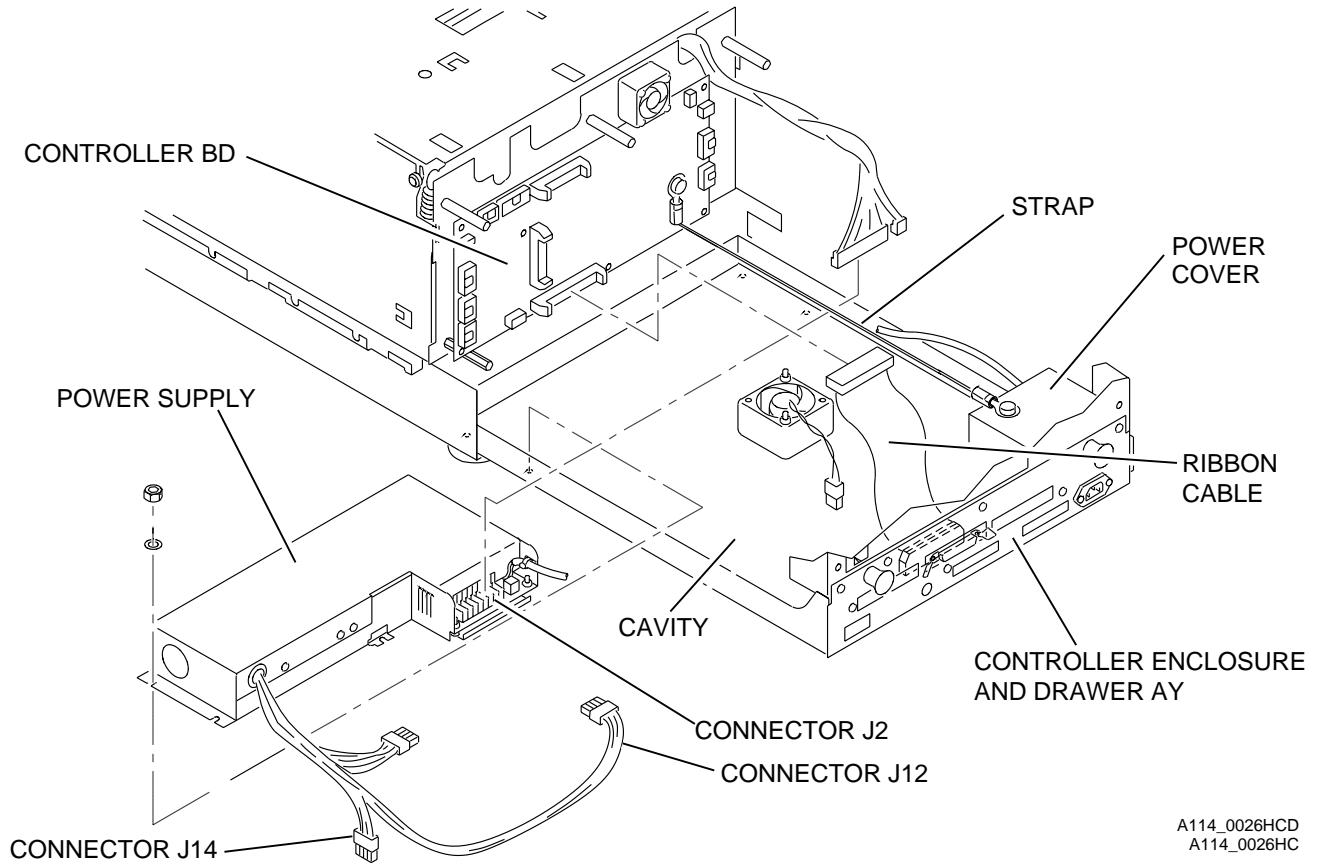

- [1] Open the CONTROLLER ENCLOSURE AND DRAWER AY. See the ADJUSTMENTS AND REPLACEMENTS, Publication No. AR3179-1.
- [2] Remove the RIBBON CABLE from the CONTROLLER BD.
- [3] Disconnect CONNECTOR J12 from the CONTROLLER BD.
- [4] Remove:
 - STRAP from the POWER COVER
 - CONNECTOR J2 from the POWER SUPPLY
 - CONTROLLER ENCLOSURE AND DRAWER AY
- [5] Use the ALCOHOL PAD to clean:
 - CAVITY
 - CONTROLLER ENCLOSURE AND DRAWER AY
- [6] Install:
 - CONTROLLER ENCLOSURE AND DRAWER AY
 - STRAP
- [7] Connect:
 - CONNECTOR J2
 - CONNECTOR J12
- [8] Install the RIBBON CABLE.
- [9] Close the CONTROLLER ENCLOSURE AND DRAWER AY.

Kodak, Image Magic, and Professional are trademarks.

